

ELITE Compact 1:

8 x ELC26 - Medium Venues, Stacked Version



Accessories:
2 x ESA1 Stacking Frame

Cabinets:
8 x ELC26
4 x E18 SUB

Controllers:
On-Board (TX20)

Total Speaker Power:
2 x 4 kW = 8 kW

Amplifiers:
1 x TX20

Horiz. Coverage:
100 degrees

Total Amp Power:
4 x 3.0 kW = 12.0 kW

ELITE Compact 2:

8 x ELC26 - Smaller to Medium Balcony Venues, Ground-Stacked Version

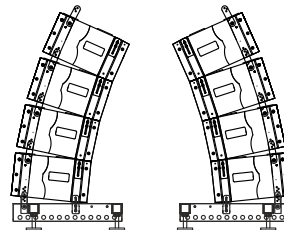

Accessories:
2 x EC1 Fly-/Stacking Frame
2 x ACS2 Set of 4 Feet

Cabinets:
8 x ELC26

Controllers:
1 x DC4000

Total Speaker Power:
2 x 2 kW = 4 kW

Amplifiers:
1 x XPS3600

Horiz. Coverage:
100 degrees

Total Amp Power:
2 x 1.8 kW = 3.6 kW

ELITE Compact 3:

8 x ELC26 - Large Balcony Venues, Stacked Version

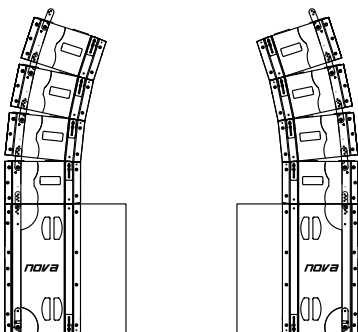

Cabinets:
8 x ELC26
2 x ELC15 SUB

Controllers:
On-Board (TX20)

Total Speaker Power:
2 x 2.6 kW = 5.2 kW

Amplifiers:
1 x TX20

Horiz. Coverage:
100 degrees

Total Amp Power:
4 x 3.0 kW = 12.0 kW

ELITE Compact 4:

8 x ELC26 - Smaller to Medium Fixed Installation, Flown Version

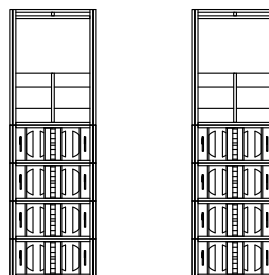

Cabinets:
8 x ELC26
2 x ELC15 SUB

Controllers:
On-Board (TX20)

Total Speaker Power:
2 x 2.6 kW = 5.2 kW

Amplifiers:
1 x TX20

Horiz. Coverage:
100 degrees

Total Amp Power:
4 x 3.0 kW = 12.0 kW

ELITE Compact 5:

16 x ELC26 - Medium to Large Fixed Installation, Flown Version

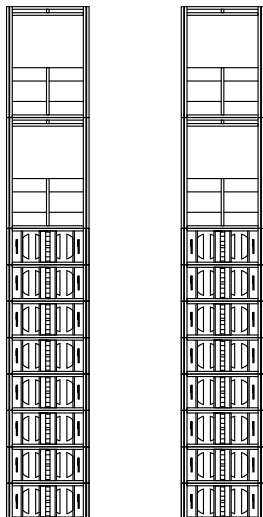

Cabinets:
16 x ELC26
4 x ELC15 SUB

Controllers:
1 x DC8000

Total Speaker Power:
2 x 5.2 kW = 10.4 kW

Amplifiers:
3 x XPS3600

Horiz. Coverage:
100 degrees

Total Amp Power:
2 x 5.4 kW = 10.8 kW

ELITE Compact 6:

8 x ELC26 - Small to Medium Venues, Flown Version

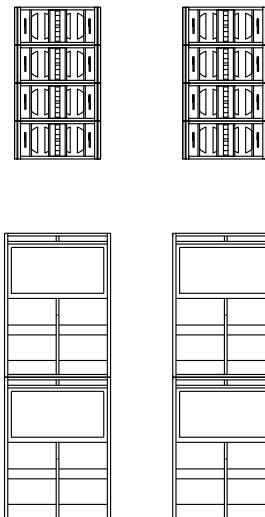

Cabinets:
8 x ELC26
4 x E18 SUB

Controllers:
On-Board (TX20)

Total Speaker Power:
2 x 4 kW = 8 kW

Amplifiers:
1 x TX20

Horiz. Coverage:
100 degrees

Total Amp Power:
4 x 3.0 kW = 12.0 kW

ELITE Compact 7:

16 x ELC26 - Medium to Large Venues, Flown Version

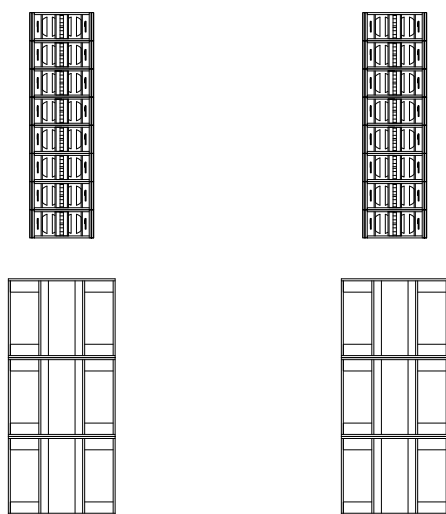

Cabinets:
16 x ELC26
6 x E218 SUB

Controllers:
On-Board (TX20)

Total Speaker Power:
2 x 10 kW = 20 kW

Amplifiers:
2 x TX20

Horiz. Coverage:
100 degrees

Total Amp Power:
8 x 3.0 kW = 24.0 kW

ELITE Compact 8:

24 x ELC26 - Large to very Large Venues, Flown Version

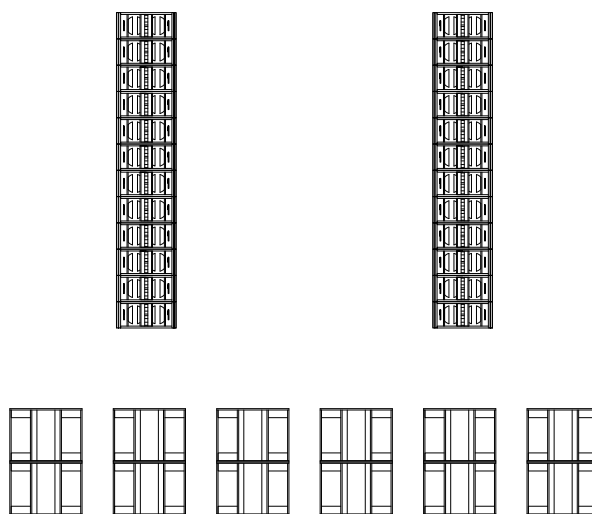

Cabinets:
24 x ELC26
12 x E218 SUB

Controllers:
On-Board (TX20)

Total Speaker Power:
2 x 18 kW = 36 kW

Amplifiers:
3 x TX20

Horiz. Coverage:
100 degrees

Total Amp Power:
12 x 3.0 kW = 36.0 kW

ELITE EL10-1:

**6 x EL10 - Smaller to Medium Venues,
Stacked Version**

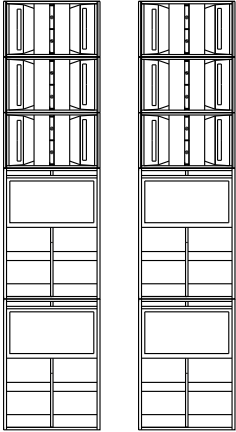

Cabinets:
6 x EL10
4 x E18 SUB

Controllers:
On-Board (TX20)

Total Speaker Power:
2 x 3.2 kW = 6.4 kW

Amplifiers:
1 x TX20

Horiz. Coverage:
100 degrees

Total Amp Power:
4 x 3.0 kW = 12.0 kW

ELITE EL15-1:

**4 x EL15 - Medium Venues,
Stacked Version**

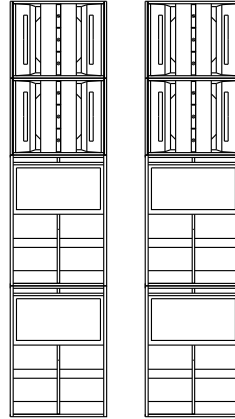

Cabinets:
4 x EL15
4 x E18 SUB

Controllers:
On-Board (TX20)

Total Speaker Power:
2 x 3.2 kW = 6.4 kW

Amplifiers:
1 x TX20

Horiz. Coverage:
100 degrees

Total Amp Power:
4 x 3.0 kW = 12.0 kW

ELITE EL10-2:

**8 x EL10 - Medium Venues,
Flown Version**

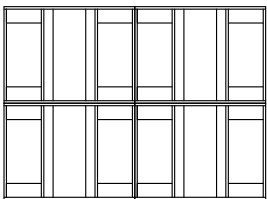
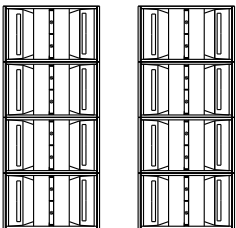

Cabinets:
8 x EL10
4 x E218 SUB

Controllers:
On-Board (TX20)

Total Speaker Power:
2 x 5.6 kW = 11.2 kW

Amplifiers:
1 x TX20

Horiz. Coverage:
100 degrees

Total Amp Power:
4 x 3.0 kW = 12.0 kW

ELITE EL15-2:

**6 x EL15 - Medium Venues,
Flown Version**

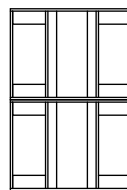
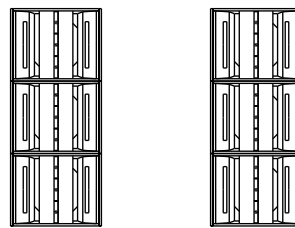

Cabinets:
6 x EL15
4 x E218 SUB

Controllers:
On-Board (TX20)

Total Speaker Power:
2 x 7.8 kW = 15.6 kW

Amplifiers:
1 x TX20

Horiz. Coverage:
100 degrees

Total Amp Power:
4 x 3.0 kW = 12.0 kW

ELITE EL10-3:

12 x EL 10 + 4 x E 15 SUB - Medium to Larger Venues, Flown Version

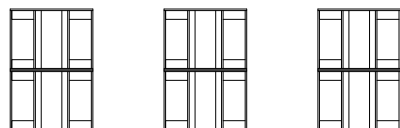
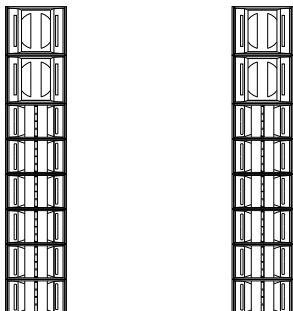

Cabinets: 12 x EL10 4 x E15 SUB 6 x E218 SUB	Controllers: 2 x DC8000	Total Speaker Power: 2 x 9.6 kW = 19.2 kW
Amplifiers: 7 x XPS3600	Horiz. Coverage: 100 degrees	Total Amp Power: 2 x 12.6 kW = 25.2 kW

ELITE EL15-3:

12 x EL 15 + 4 x EL 10 - Larger Venues, Flown Version

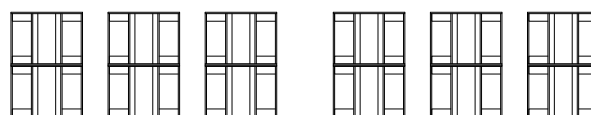
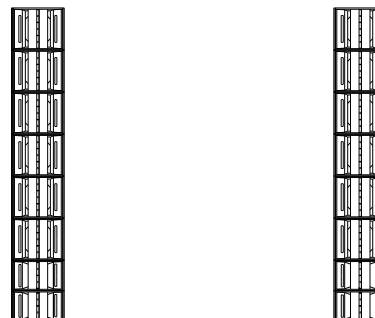

Cabinets: 12 x EL15 4 x EL10 12 x E218 SUB	Controllers: On-Board (TX20)	Total Speaker Power: 2 x 16.4 kW = 32.8 kW
Amplifiers: 3 x TX20	Horiz. Coverage: 100 degrees	Total Amp Power: 12 x 3.0 kW = 36.0 kW

PROJECT SUPPORT

The professional NOVA Customer Service.



ELITE ist ein modular aufgebautes System und kann in Größe und Zusammenstellung variiert werden. Der NOVA Kundensupport konfiguriert nach Anforderung individuelle Systemvarianten. Ob für die mobile Rental- bzw. Band-Anwendung oder für die Festinstallation: Der NOVA Kundensupport steht Ihnen mit Rat und Tat zur Seite.

Dazu benötigen wir zunächst einigen Angaben:

- ▶ Art der Beschallung (Sprachbeschallung, Musikrichtung, etc.)
- ▶ Mobiles System oder Festinstallation
- ▶ Maximal zu beschallende Zuhörerzahl
- ▶ Vollständige Adresse mit Telefonnummer

Sofern Sie eine Konfiguration für eine Festinstallation wünschen, senden Sie uns dazu auch die Pläne und Zeichnungen der zu beschallenden Räumlichkeiten.

Nach Erhalt Ihrer Daten und Unterlagen setzen wir uns mit Ihnen kostenfrei und unverbindlich in Verbindung.

Email-Adresse: info@novacoustic.de
Telefonnummer: +49 (0) 85 31 / 31 71 - 0

Weiterführende Informationen und Supportdaten finden Sie auch im Supportbereich auf der NOVA Website:
www.novacoustic.de/html/support.html



ELITE is a modular system and can be varied in size and composition. The NOVA customer service configures individual system variants as required. Whether for mobile rental- or band application or for fixed installation: The NOVA customer support is available with help and advice.

To create an application we first need some information:

- ▶ Type of PA (public address, genre of music, etc.)
- ▶ Mobile system or permanent installation
- ▶ Maximum number of listeners
- ▶ Address and phone number

If you wish a configuration for a permanent installation, please send us also the plans and drawings of the building or hall.

Upon receipt of your data and documents we will contact you free of charge and without any obligation.

Email: info@novacoustic.de
Phone: +49 / 85 31 / 31 71 - 0

Additional information and support data can be also found in the support area on the NOVA website:
www.novacoustic.com/html/support.html